



MUSASHI
ENGINEERING, INC.

Non contact for low viscosity fluids jet dispenser

CyberJet[®] 2

Newly developed.
Jetting micro amount of
low viscosity
fluids without scatter.

Redesigned **CyberJet[®] 2**, now it is available

NEW

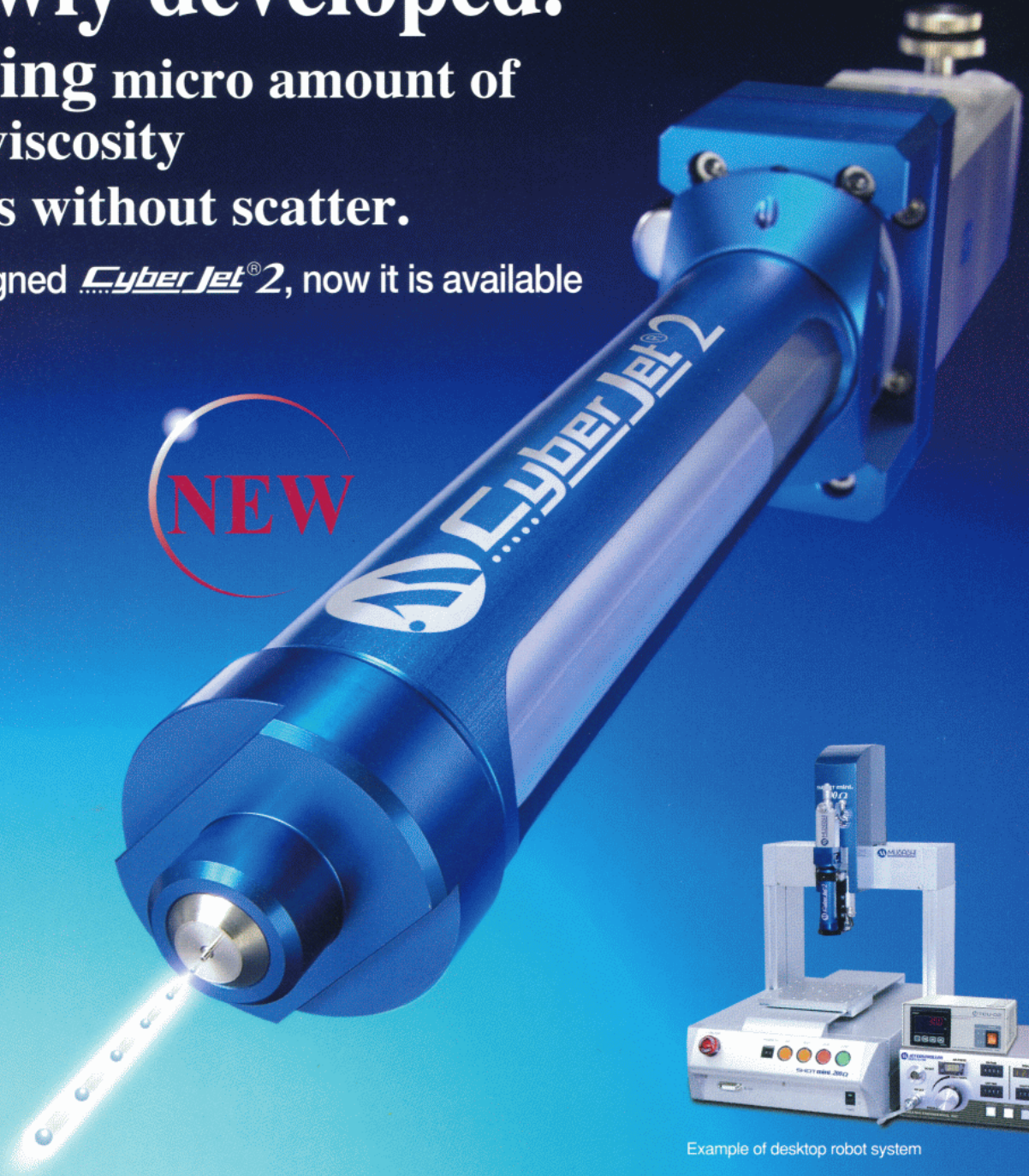

Example of desktop robot system

Dispense Applications

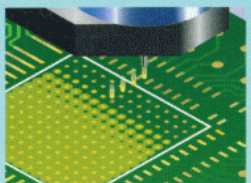

Flux dispensing on PCB

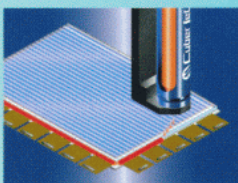

Resin dispensing to liquid crystal FPC terminal part

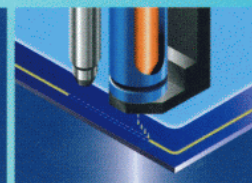

A seal dispensing on LCD board

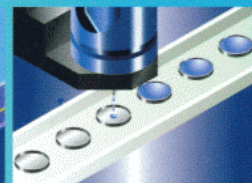

Fill solution on a button battery

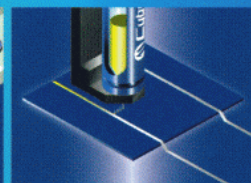

Flux dispensing to photovoltaic cell

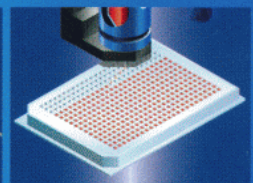

Non-contact dispensing to microwell plate

CyberJet[®] 2 Newly developed.

Jetting micro amount of low viscosity fluids witho

For "Minimum amount" and "Non-contact" dispensing.
CyberJet has been renewed to meet your needs for genuine quality.

Feature 1 Achieved micro amount dispensing of **0.03mg**. **Minimum in class.**

Feature 2 Achieved high-speed dispensing takt time of **133shot/sec**. **Fastest in class**

Feature 3 Highly precise non contact JET dispensing of low viscosity fluids.

Striking differences compared to airpulse system dispensers!!

- **Liquid drip-free!**

Since the liquid flow path closes automatically after dispensing, low viscosity liquid materials can be dispensed without dripping.

- **No need for gap management!**

Since the gap between work and nozzle does not influence dispensing amount, gap management is unnecessary.

- **High takt time attained!**

Because of our non-contact dispensing technology, there is no need to raise or lower the nozzle, realizing high-takt dispensing.

Dispensing accuracy by CyberJet[®] 2

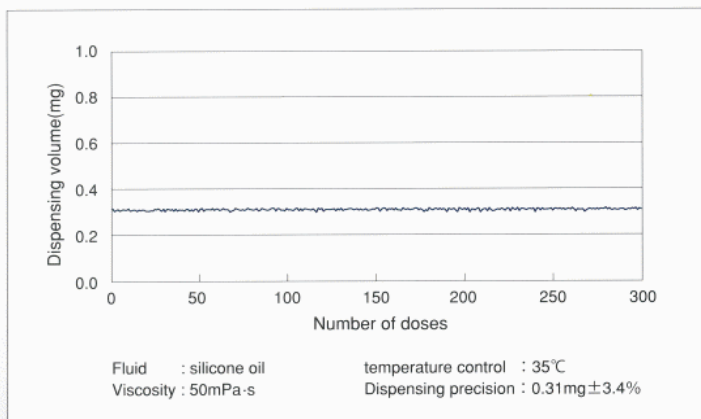

Actuator

Adapter

Syringe holder

Nozzle heating function preinstalled

Nozzle



at scatter.

Dispense Head

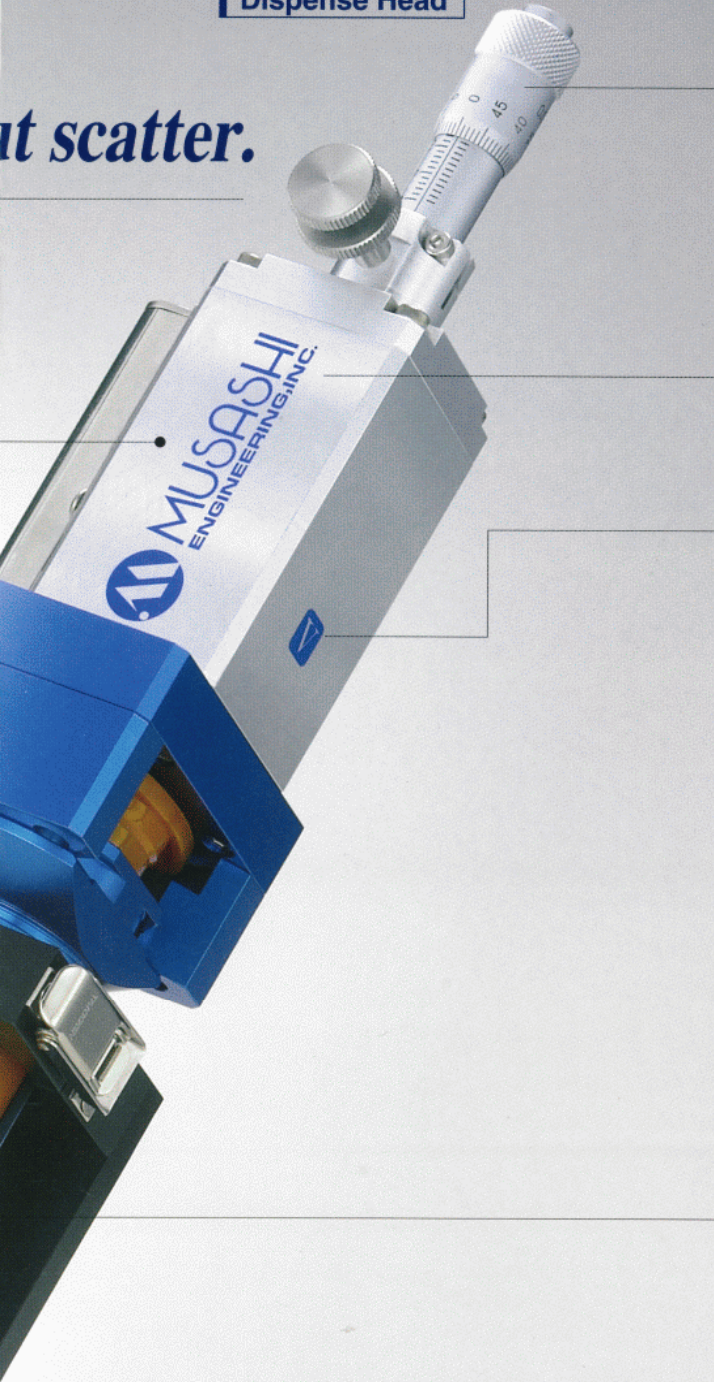

Easy and accurate rod stroke adjustment. **Cyber Jet 2 New Feature**

Rod stroke adjustment for adjusting dispense amount can be adjusted visually and accurately by micrometer scale.

Adopts Electromagnetic valve system to reduce air consumption.

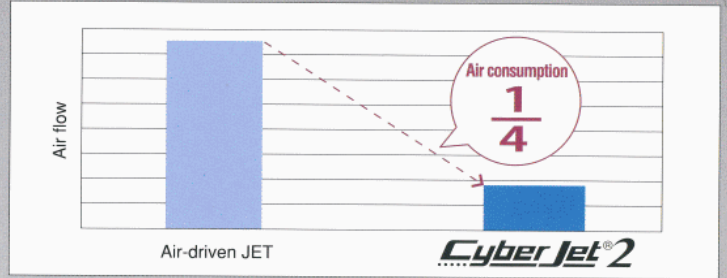

Ultra-silent dispensing made possible by original actuator structure.

Actuator can be selected from 3 types according to liquid material or use. **Cyber Jet 2 New Feature**

Type I Standard type for wide range of application

Type III For relatively low-viscosity fluids

Type V For low-viscosity fluids (1 to 100 mPa.s) such as reagent and ink

Syringe holder can be selected from 5 types.

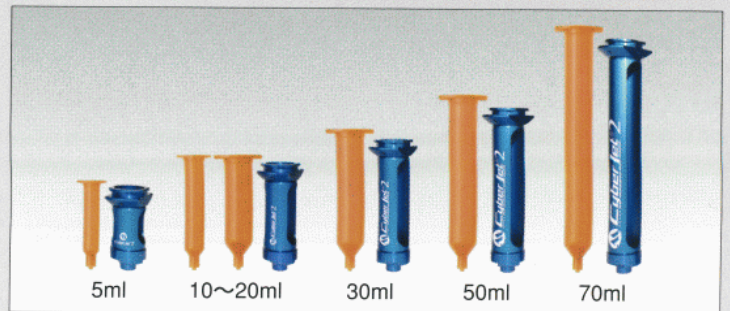

*The syringe shown above is UV block syringe.

Dispense controller

Holder

Switching between dispensing mode of "Line dispensing" and "Dot dispensing" made simple by one touch of a button.

LINE dispense mode

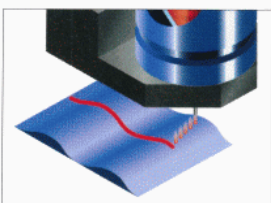

Line formed with continuous high-speed micro amount dispensing.

DOT dispense mode

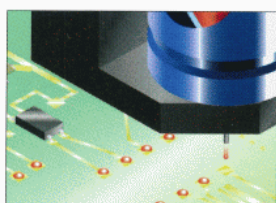

Dot dispensing at arbitrary intervals made possible by trigger signal.



TCU-02 Dedicated temperature controller for nozzle heating.



Specifications

Dispense Head

Name	CyberJet2 head
Model	MJET-C-2-HU○-△-□*
Driving system	electromagnetic
Supply air pressure	0.5MPa or less
Connecting syringes	all size (5 to 70ml) applicable
Applicable fluids	Flux, Moisture proof insulant fluid, UV resin etc.
Use nozzle	Pipe type (1L,2L,3L): 15 to 32G
	Pipe type (1L,2L,3L): 15 to 28G Teflon coated
	Integral structure (SHN): 28 to 36G
Temperature control system	Holder equipped with heating temperature control

* ○ : 5, 10, 20, 30, 50, 70(select syringe size)
 △ : L, R(select connector position)
 □ : I, III, V(select actuator)

Dispense controller

Name	Jet controller	
Model	MJET-3-CTR	
Control method	Electro/pneumatic method	
Dispensing pressure regulating range	0.005~0.700MPa	
Control circuit of dispensing time	Digital timer circuit	
Dispensing time setting range	Dot mode	2~5,000msec
	Line mode	Turning on time : 1.50~99.99msec Turning off time : 6.00~99.99msec
Dispensing frequency setting range	1to 1,000 times (for Line mode)	
Supply pressure	Max0.800MPa	
Rated power supply and frequency	AC100~240V 50/60Hz	
Weight	4kg	

Temperature controller

Name	Temperature controller
Model	TCU-02
Control method	2 Flexibility PID or ON/OFF
Sensor	Resistance bulb
Temperature adjustable range	30 to 100°C (At ambient air temperature of 25°C)*
Power supply voltage	AC100V 50/60Hz
Weight	1,040g

*Cyber Jet 2 can be used at range 30~60°C.

External dimensions

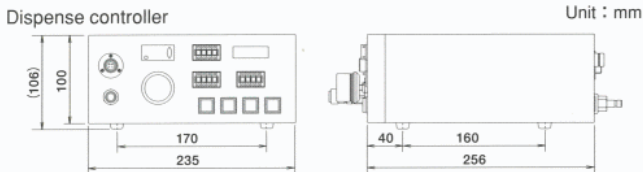

Syringe size	A	B	Weight	○	□
5ml	222	65	660g	5	
10, 20ml	247	80	680g	10, 20	I
30ml	272	105	700g	30	III
50ml	303	135	730g	50	V
70ml	366	200	780g	70	

*As for L type, connector will be positioned on the left.

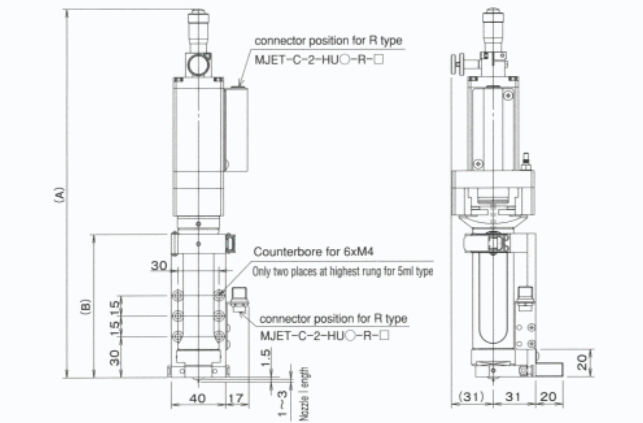

*External dimensions shown above is for R type

Temperature controller

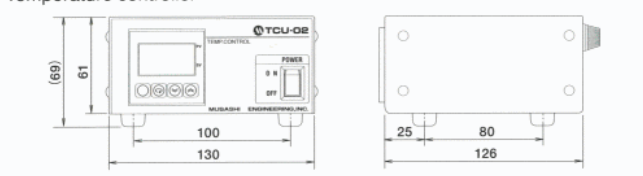

Component parts of Head



Safety precaution
 Make sure to read the instruction manual before you use the unit, for your safety.

* We reserve the right to change the specifications without notice.
 * All copyrights are retained by MUSASHI ENGINEERING. Reprinting, reproducing, and/or transmitting as electronic data in whole or in part these material without prior written permission is strictly prohibited.



世界のディスペンサー

武蔵エンジニアリング株式会社
 MUSASHI ENGINEERING, INC.

HEAD OFFICE
 8-7-4, Shimorenjaku, Mitaka-shi, Tokyo, 181-0013, Japan TEL : (81)422-76-7111 / FAX : (81)422-76-7122
BRANCH
 TOKYO, OSAKA, NAGOYA, SENDAI, FUKUOKA, SAITAMA, NAGANO, EAST-KANTO, AKITA, KANAZAWA

<http://www.musashi-engineering.co.jp/>

autorisierter Vertriebspartner für Deutschland

ATN Automatisierungstechnik Niemeier GmbH



Segelfliegerdamm 94-98
 D-12487 Berlin, Germany

Tel.: ++49 30 565 9095-0
 Fax: ++49 30 565 9095-60

mail: info@atn-berlin.de
 web: www.atn-berlin.de